

garbaruk

Universal crankset installation manual

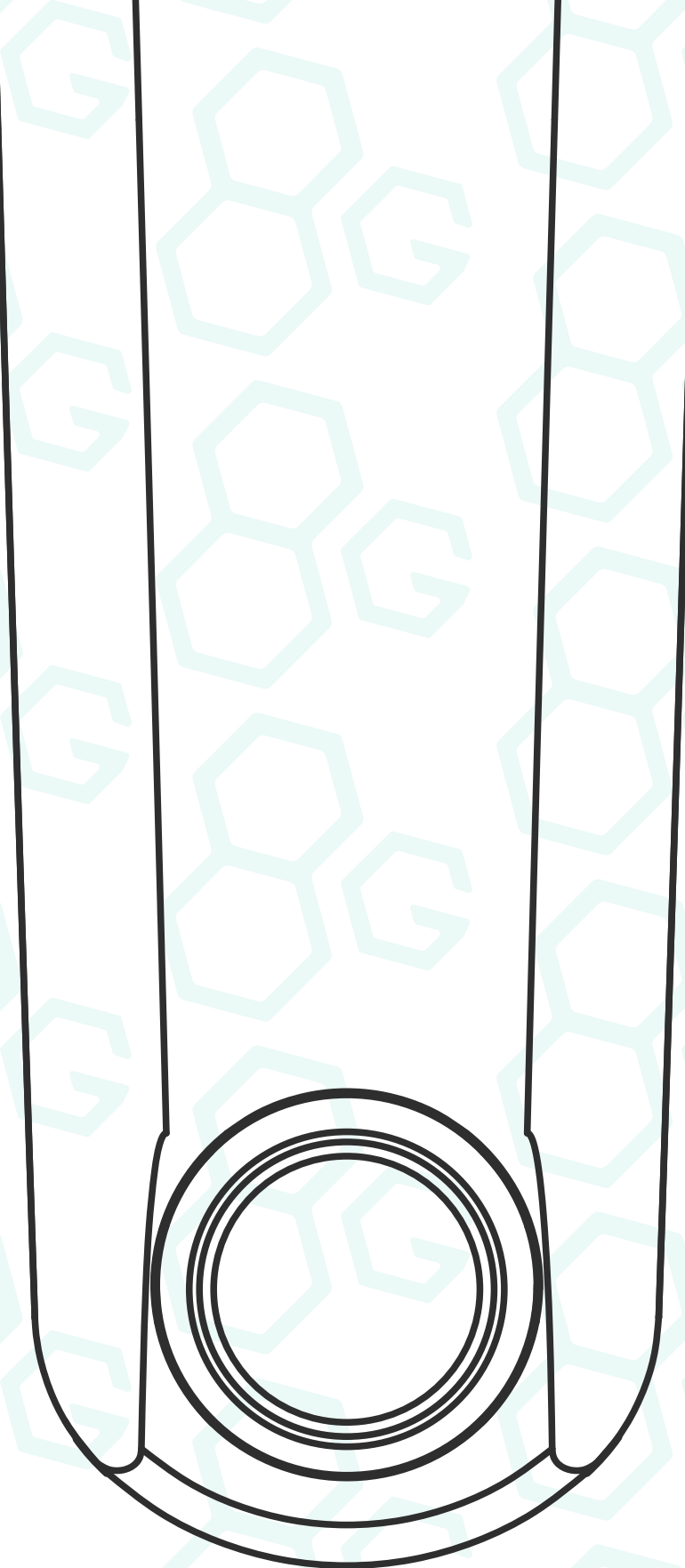

Contents

0. List of parts

1 – 7. Installation

8. Additional information

9. Bottom bracket compatibility table

10 – 15. How to choose the right spacer rings for your bike

Tools needed for installation:

- Enduro CT-001 or Shimano TL-FC33, or similar bottom bracket tool.
- 12mm HEX key.
- 2mm HEX key.

List of parts

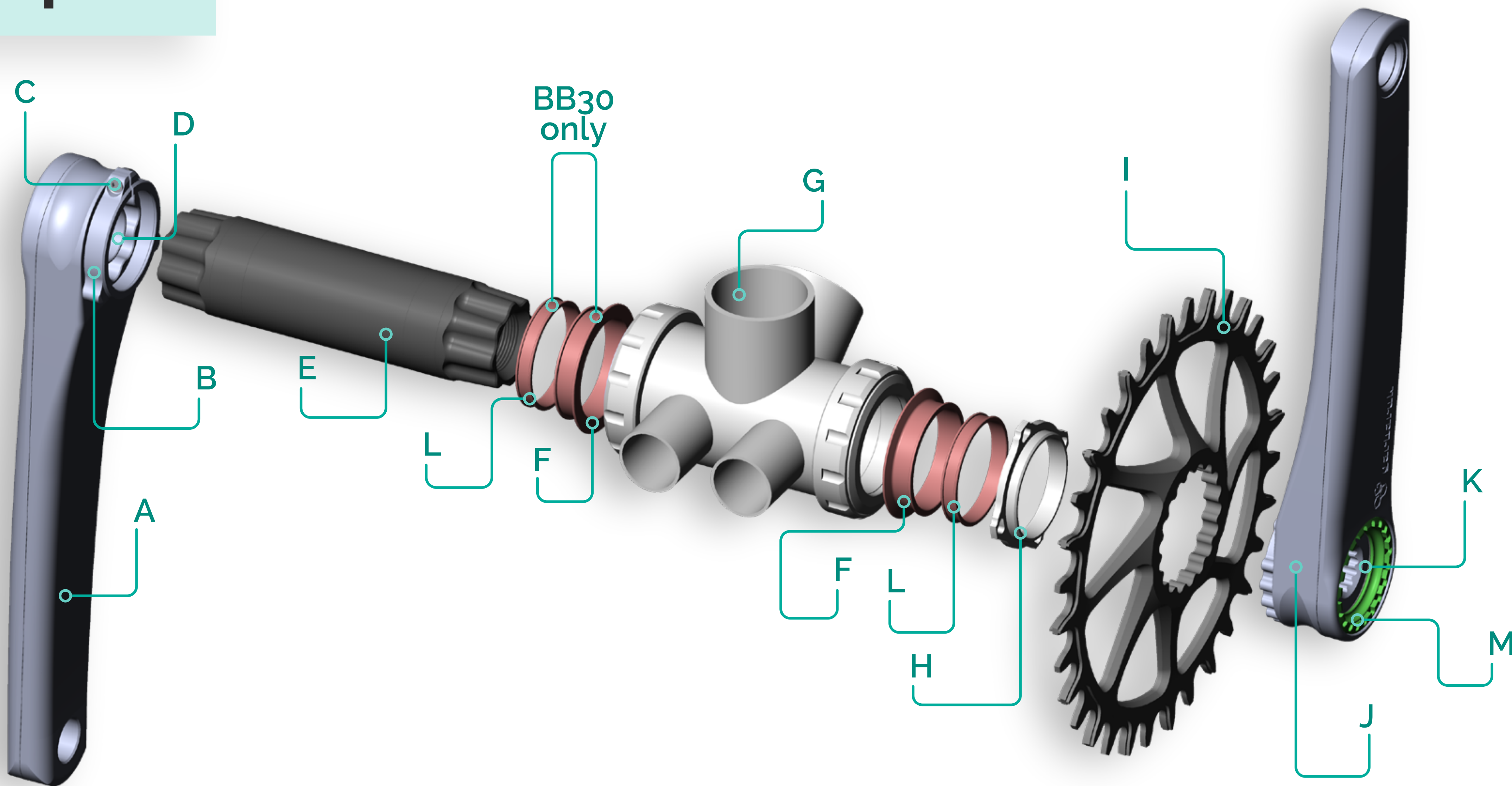

Step 1

On the non-driveside crankarm, turn the preload adjuster (B) until it gently touches the crankarm (A).

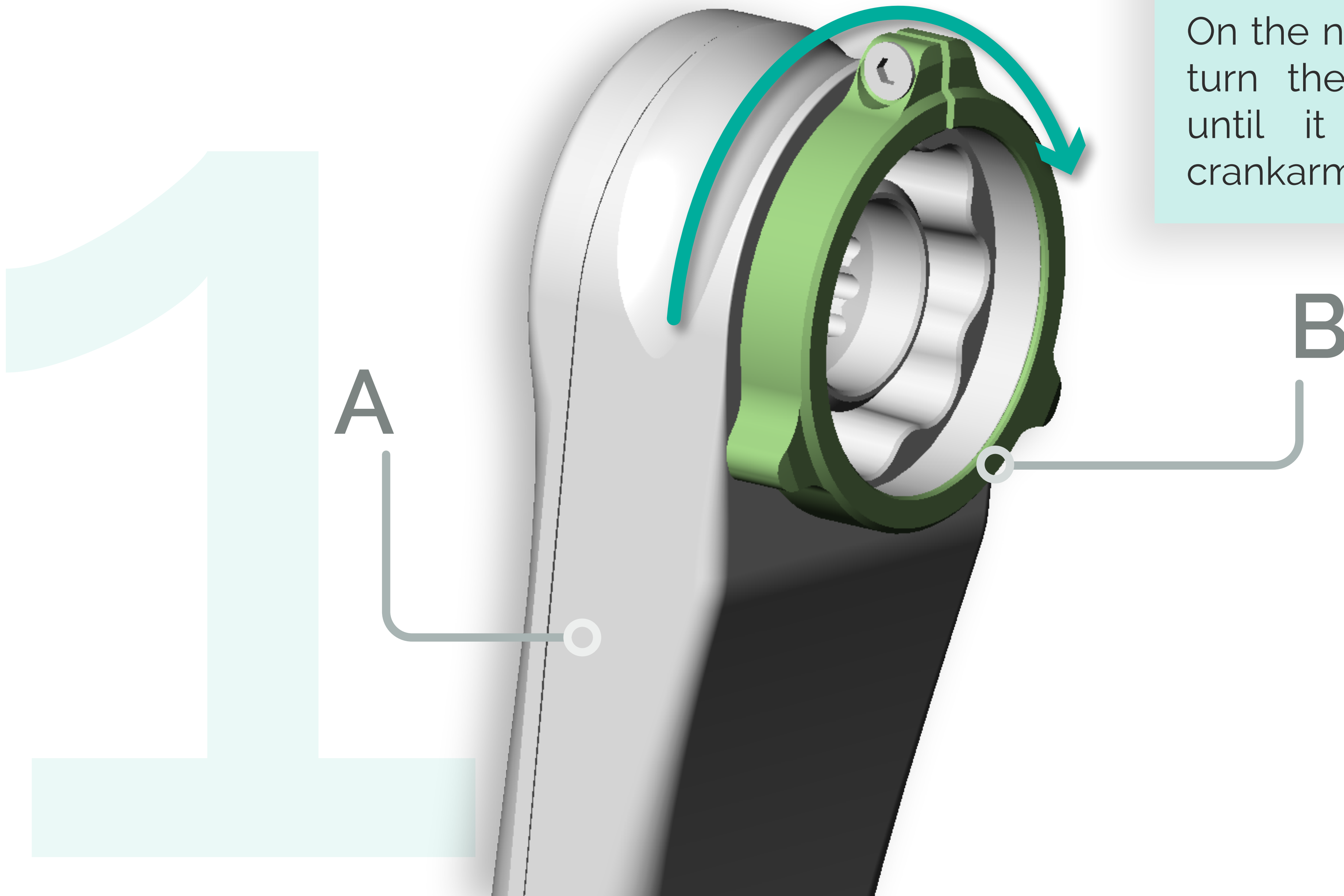

Step 2

Mount the chainring (I) on the driveside crankarm (J).

Put some grease on the mounting surface (highlighted in yellow) before installing the chainring.

To secure the chainring, use the crankset lockring (H) and Enduro CT-001 / Shimano TL-FC33 or similar bottom bracket tool. Recommended tightening torque: 35Nm.

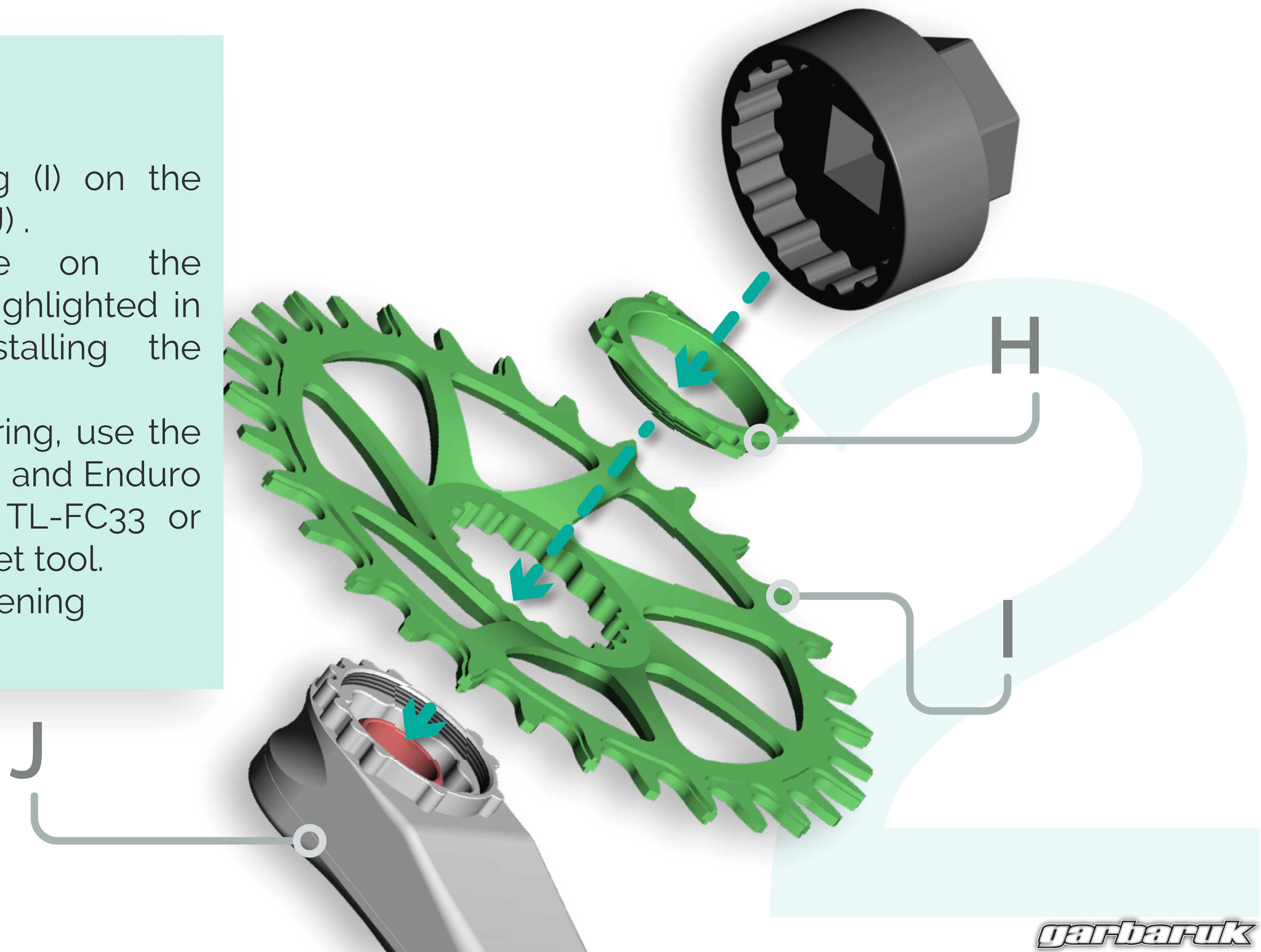

Hex key

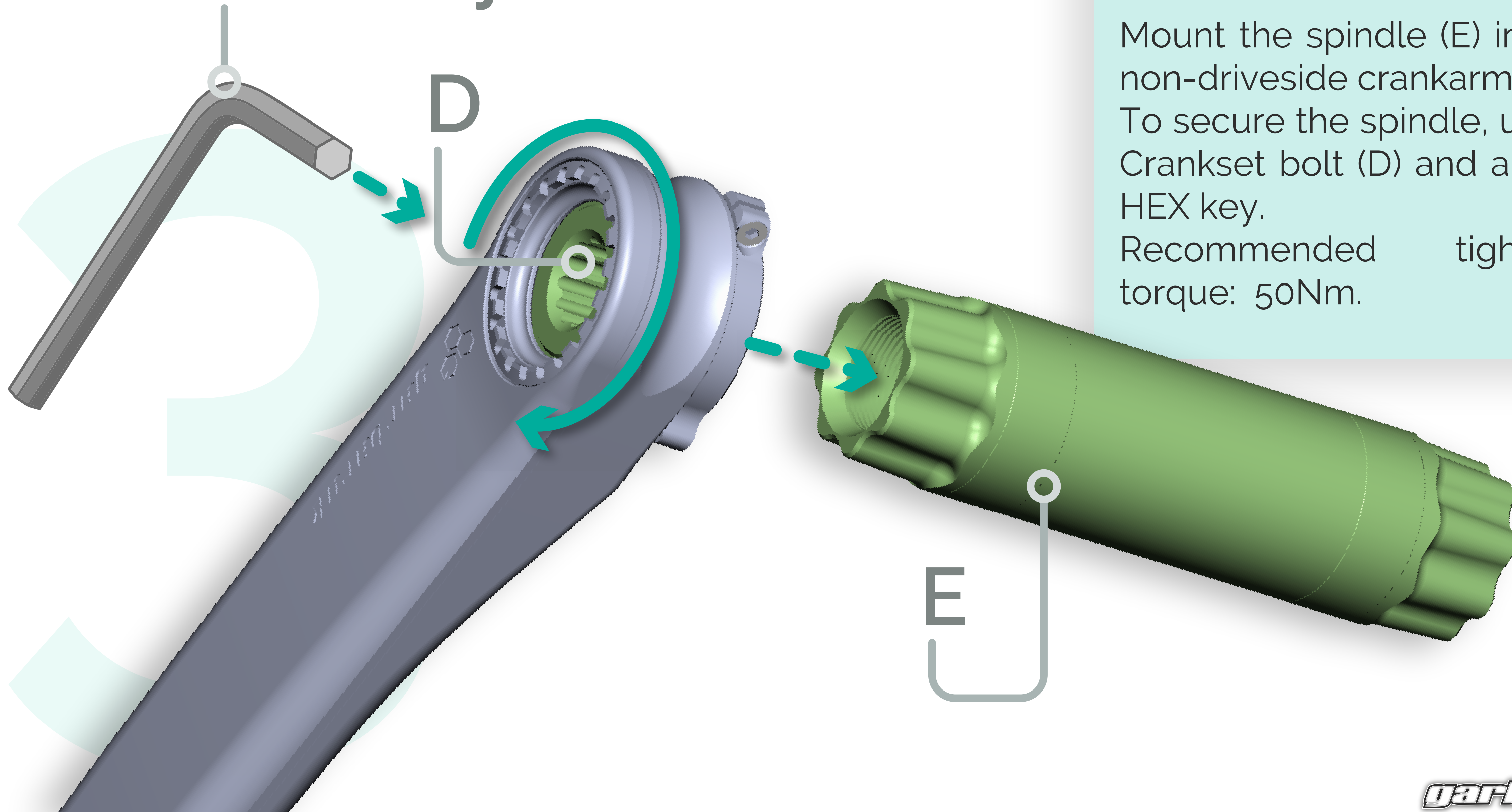

Step 3

Mount the spindle (E) into the non-driveside crankarm (A). To secure the spindle, use the Crankset bolt (D) and a 12mm HEX key. Recommended tightening torque: 50Nm.

Step 4

Insert the spindle into your bottom bracket (G). Spacer rings may be needed, depending on the bottom bracket standard. For guidance, please check "bottom bracket compatibility table" below.

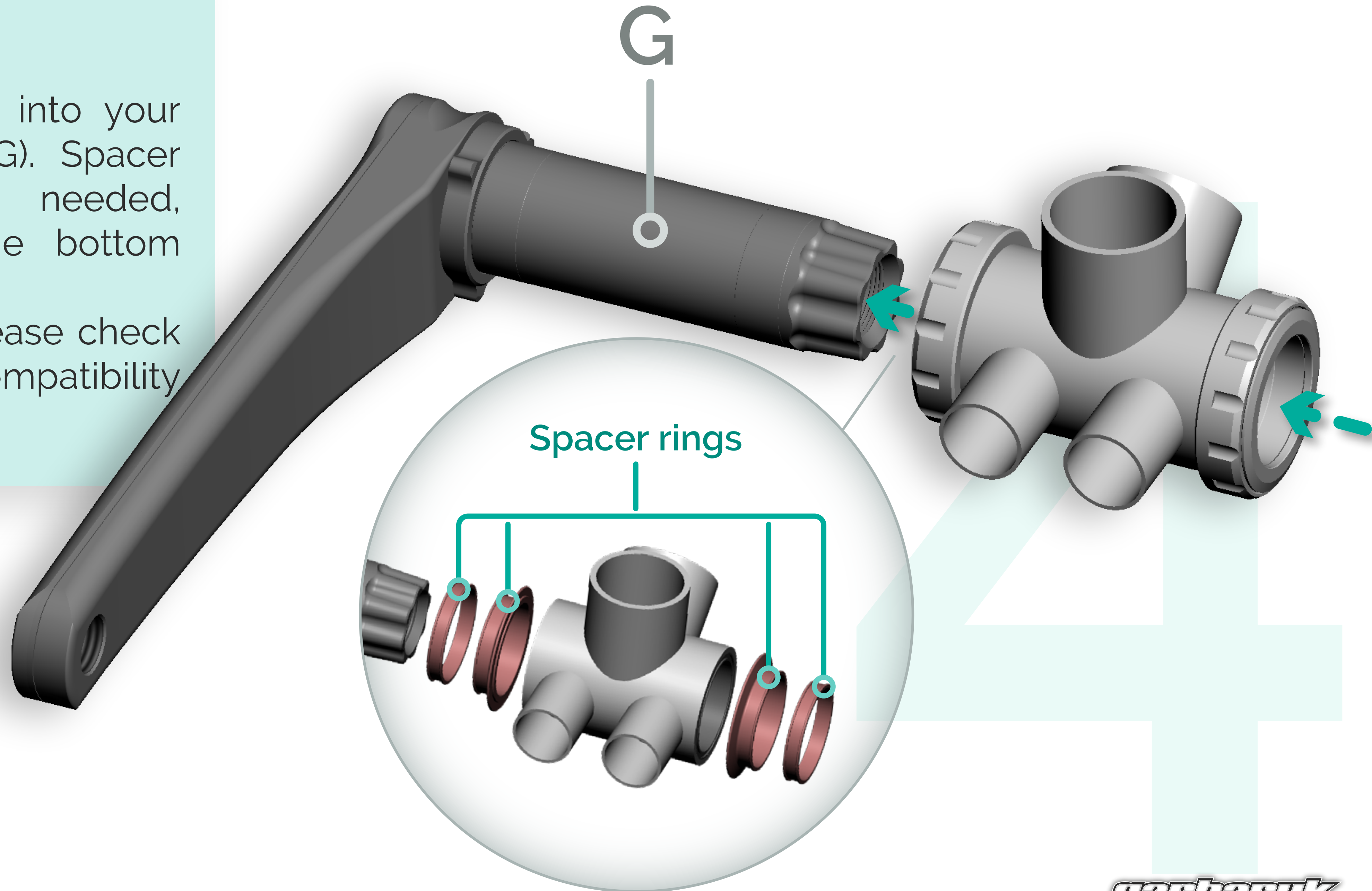

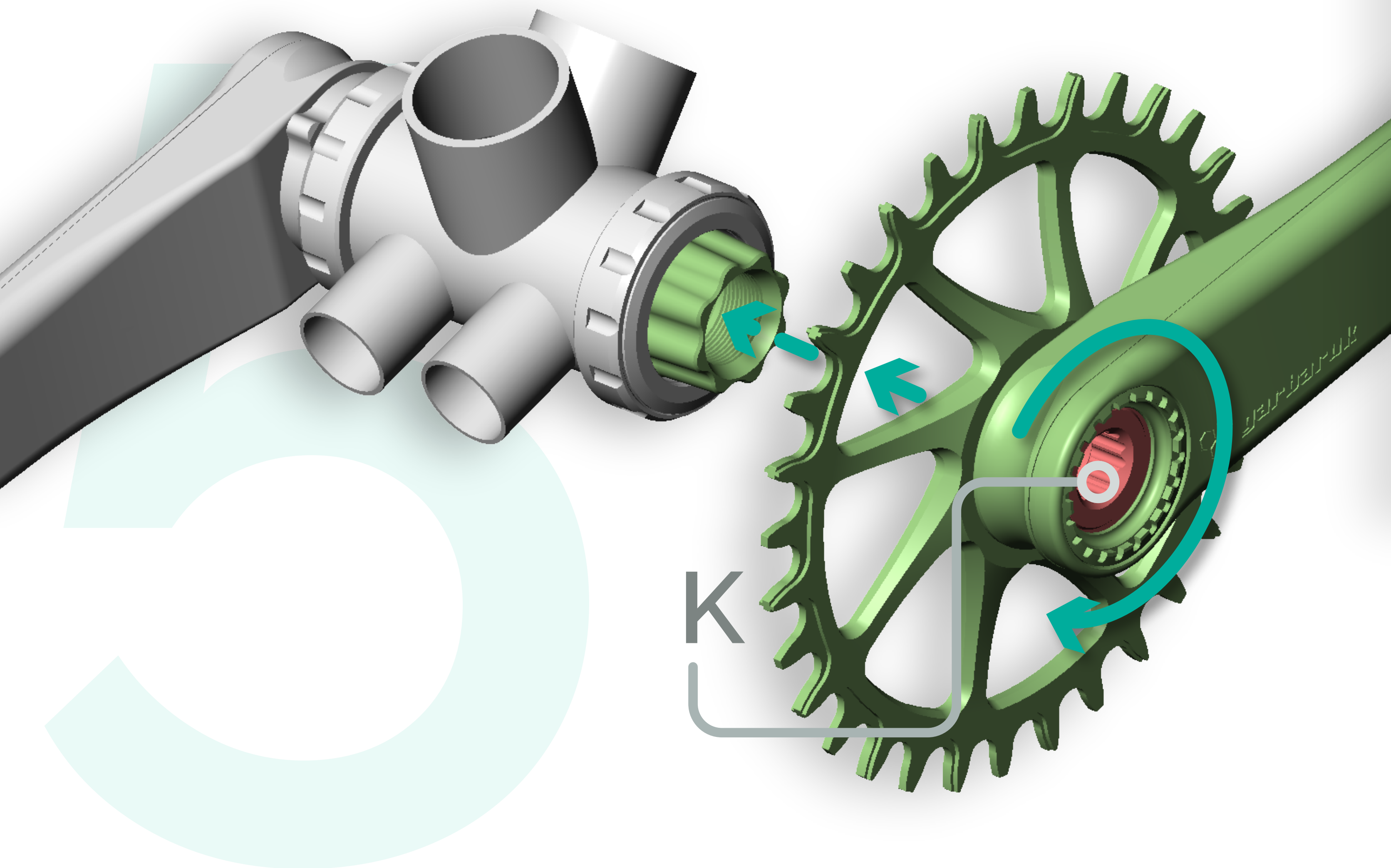

Step 5

Mount the driveside crankarm. Secure by tightening the crankset bolt (K) with a 12mm HEX key.

Recommended tightening torque: 50Nm.

Gently push on the crankarm in the direction of the bottom bracket to get it into the correct position.

Step 6

Rotate the preload adjuster (B) until it's in contact with your bottom bracket (G).

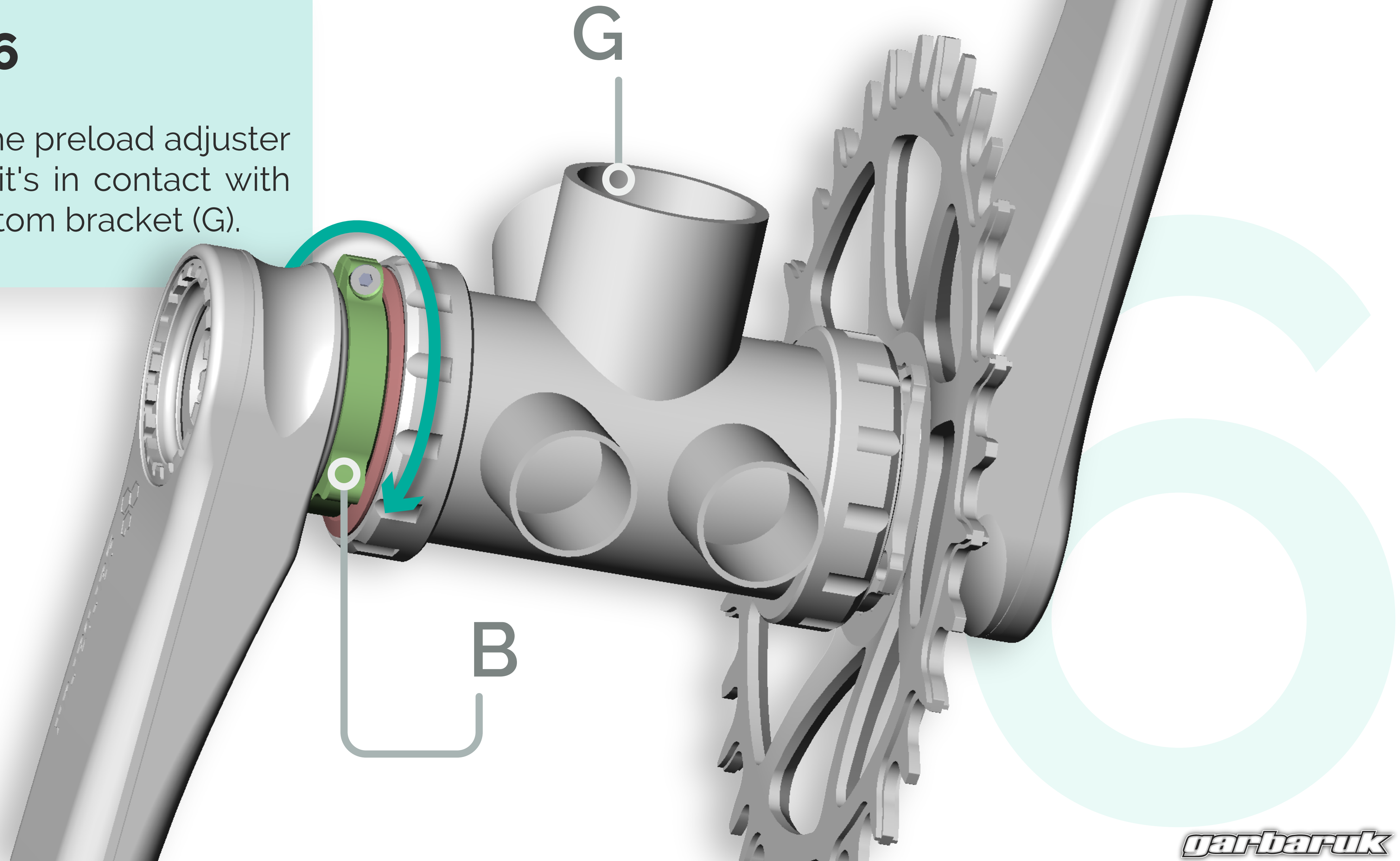

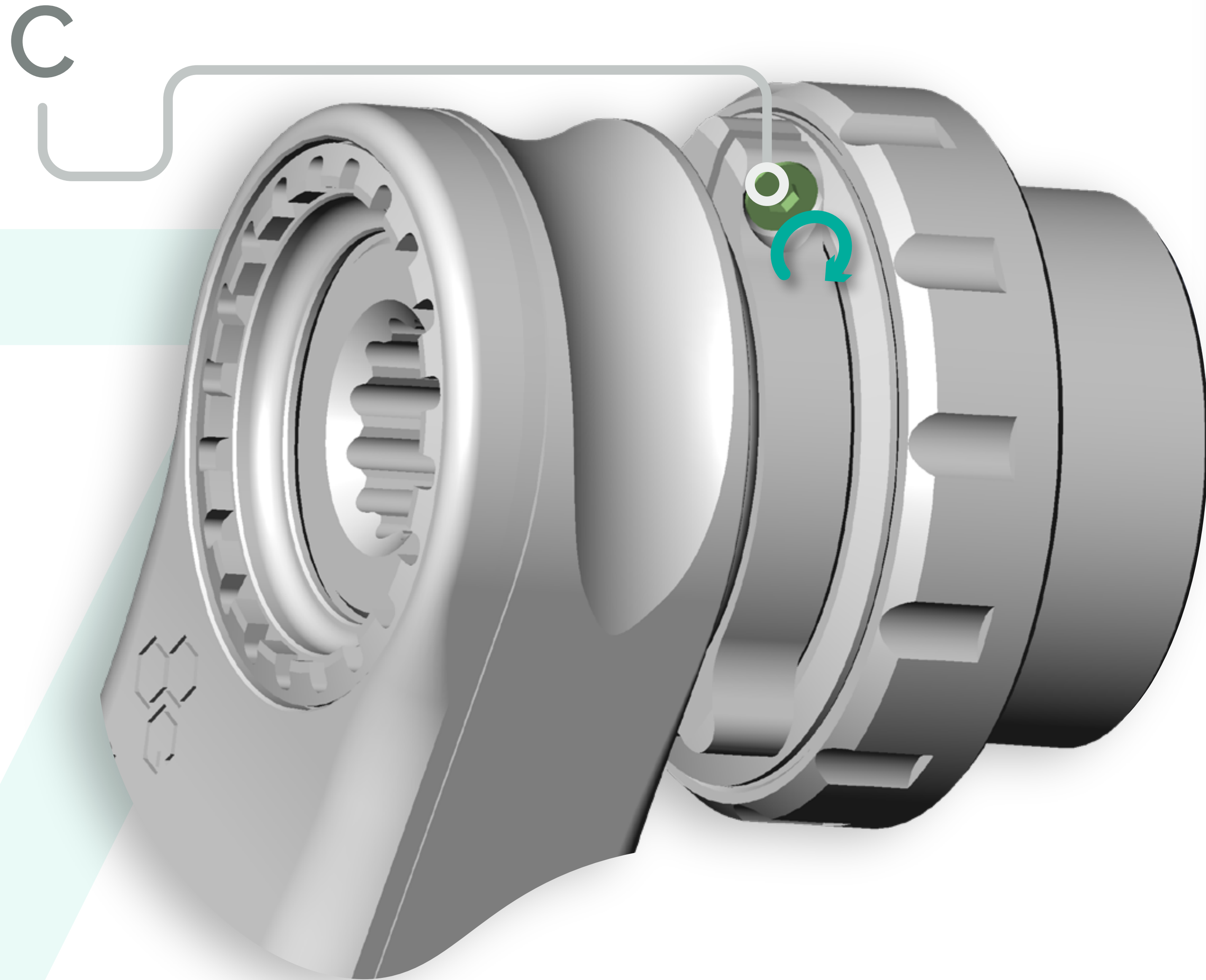

Step 7

Tighten the securing bolt (C) on the preload adjuster by using a 2mm HEX key. Recommended tightening torque: 1-1.5Nm.

Additional information

- To remove the crankset, untighten the K bolt (highlighted in red). There is no need to untighten the self-extractor (M, Highlighted in yellow) to remove the chainring.

- To remove the self-extractor, use a ParkTool BBT32 key, or similar. Turn clockwise, as it has left-handed thread. Recommended tightening torque for self-extractor: 15-20Nm. We also recommend using a light threadlocker.

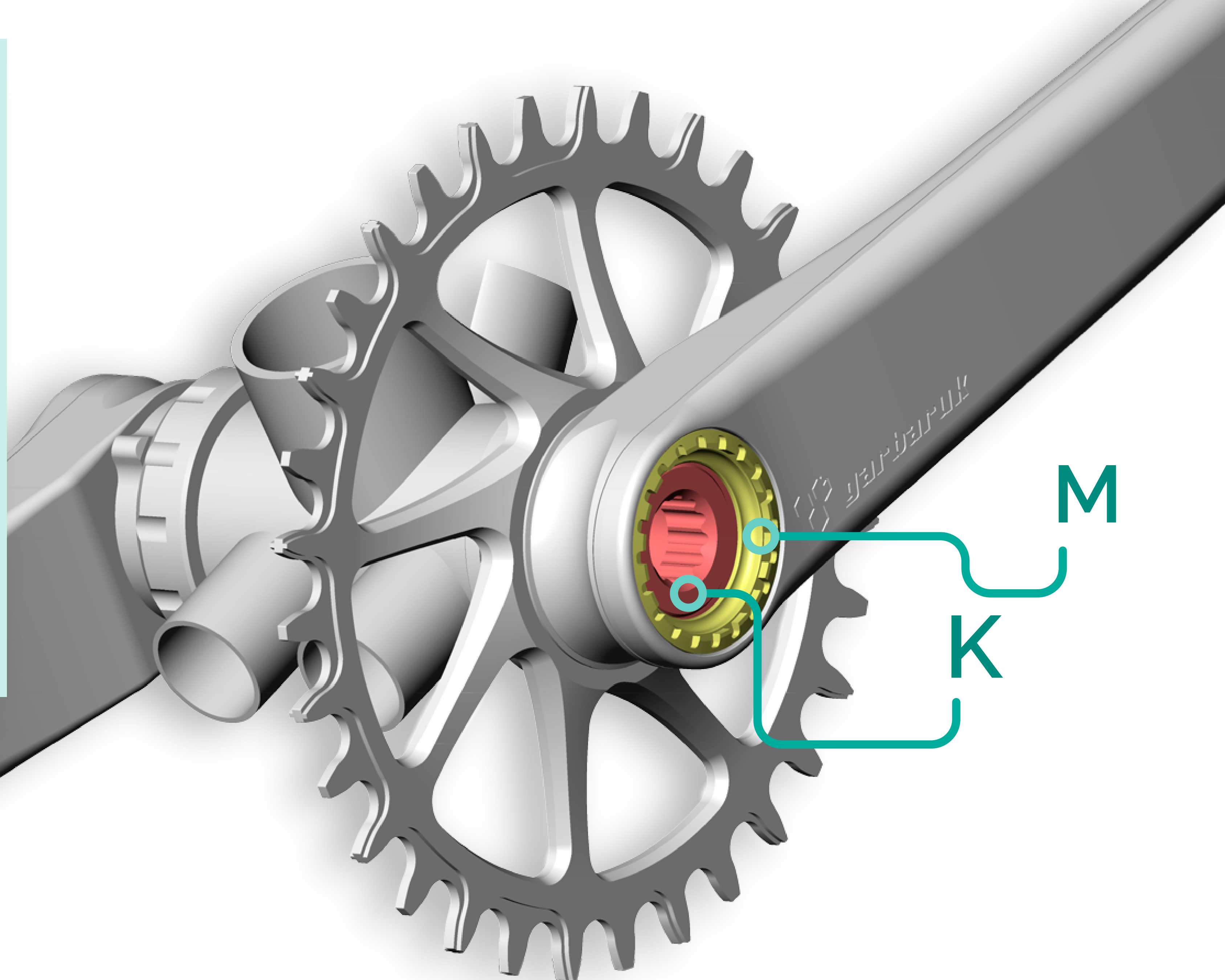

Bottom bracket compatibility table

	Spindle D30			Spindle D29 (SRAM_DUB)		
	MTB Spindle 136,5 CI 52	Road/Gravel Spindle 130,5 CL45/47,5	MTB Spindle 140,5 CI 55	MTB Spindle 136,5 CI 52	Road/Gravel Spindle 136,5 CL45/47,5	MTB Spindle 140,5 CI 55
BSA 68	✓	✓	✓	✓	✓	✓
BSA 73	✓		✓	✓		✓
T47 68 External		✓			✓	
T47 73 External	✓		✓	✓		✓
T47 73 Internal	✓		✓	✓		✓
T47 83 Internal	✓		✓	✓		✓
T47 85,5 Internal		✓			✓	
T47 86,5 Internal		✓			✓	
T47 89,5 Internal	✓		✓	✓		✓
T47 92 Internal	✓		✓	✓		✓
PF30-68 (PressFit D46)		✓			✓	
PF30-73 (PressFit D46)	✓	✓	✓	✓		✓
PF30-83 (PressFit D46)	✓		✓	✓		✓
BB 386 86,5 (PressFit D46/ PF386)		✓			✓	
BB 392 92 (PressFit D46/ PF392)	✓		✓	✓		✓
BB86 D41/86,5 (PressFit D41)		✓			✓	
BB89,5 D41/89,5 (PressFit D41)	✓		✓	✓		✓
BB92 D41/92 (PressFit D41)	✓		✓	✓		✓
BB30 (PressFit D42) 68		✓			✓	
BB30 (PressFit D42) 68	✓	✓	✓	✓		✓
BB30 (PressFit D42) 83	✓		✓			

How to choose the right spacer rings for your bike

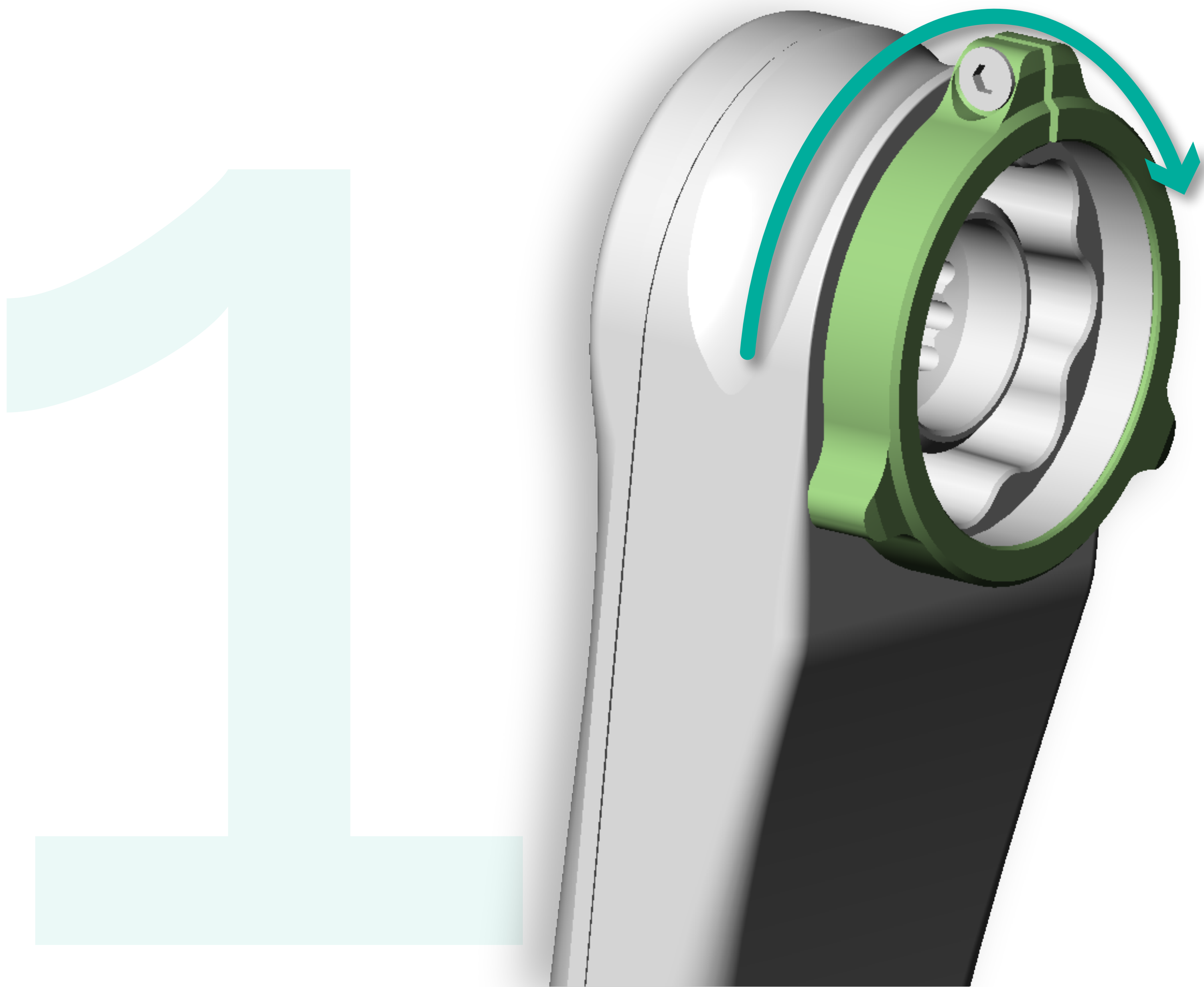

Step 1

On left crank tighten the nut until it contacts the crank.

Step 2

On right crank Install chainring and tighten the nut.

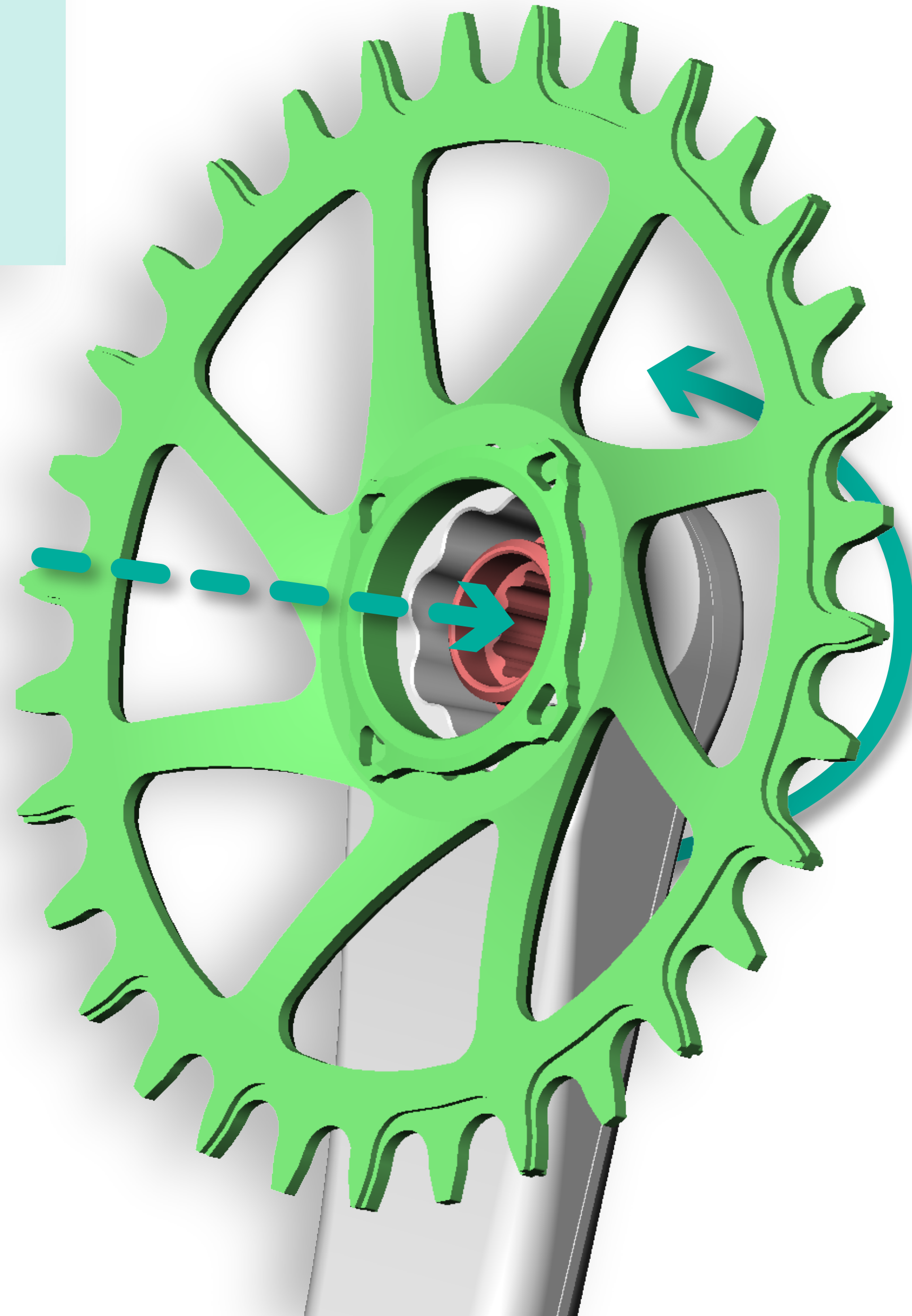

No spacers

No spacers

Step 3

Install cranks in the same direction and tighten the bolts with a torque of 50n/m. Do not install spacers.

Hex 12mm
50 H/M

Step 4

Measure the distance from cranks to the rim on both sides.

Distance from the cranks to the rim must be the same on both sides.

If the distances are different, gently tap the cranks to achieve the same distance from both sides.

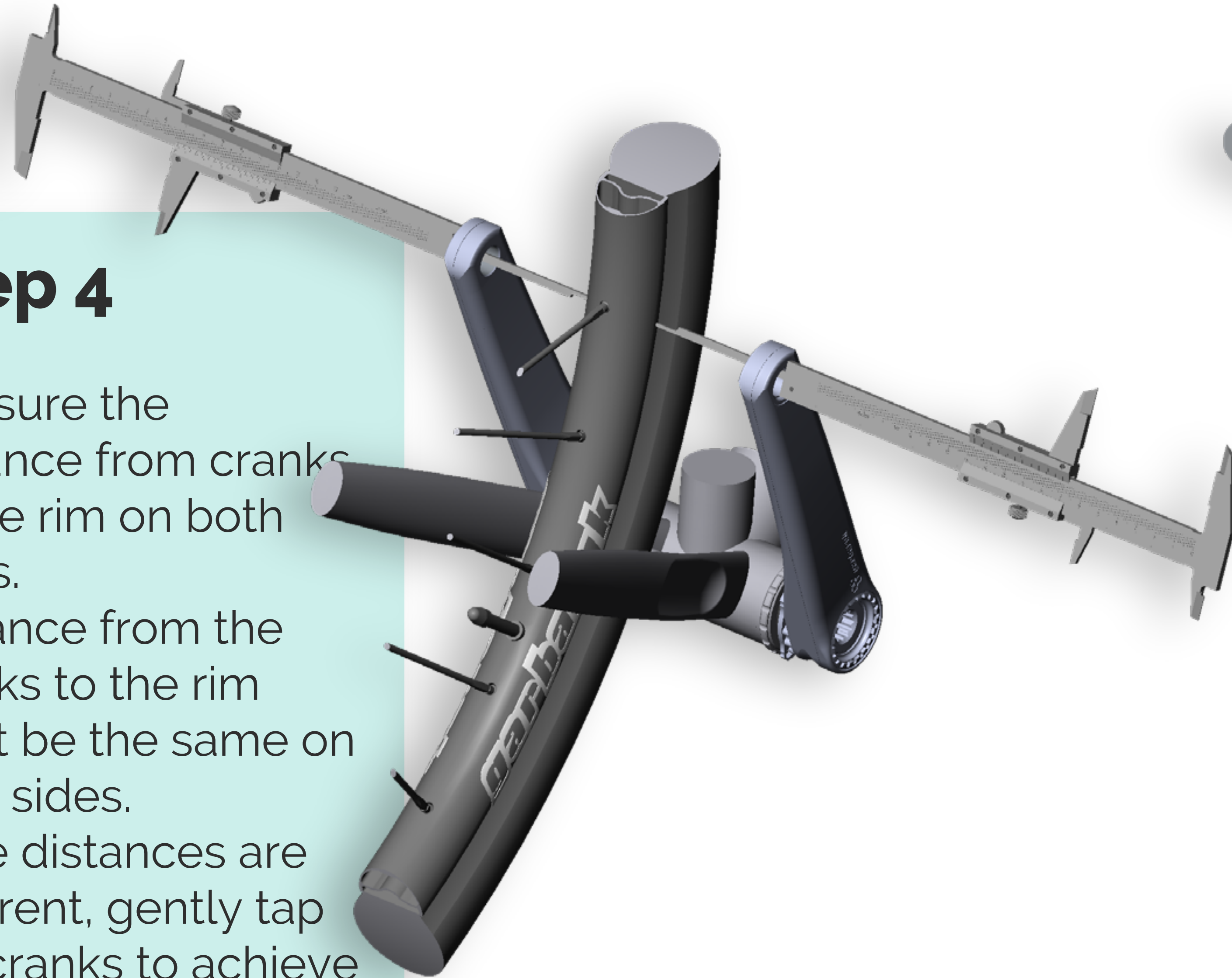

Step 5

Measure the clearance between cranks and bottom bracket.
Fit the spacer rings from the kit.
Fit the rings so that there is enough clearance for adjustment with the adjusting nut.

